

RTH 6.31



CONSTRUCTION



LOGISTICS

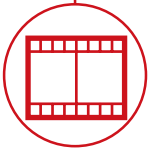

EVENTS AND
FILM



FORESTRY



RTH 6.31

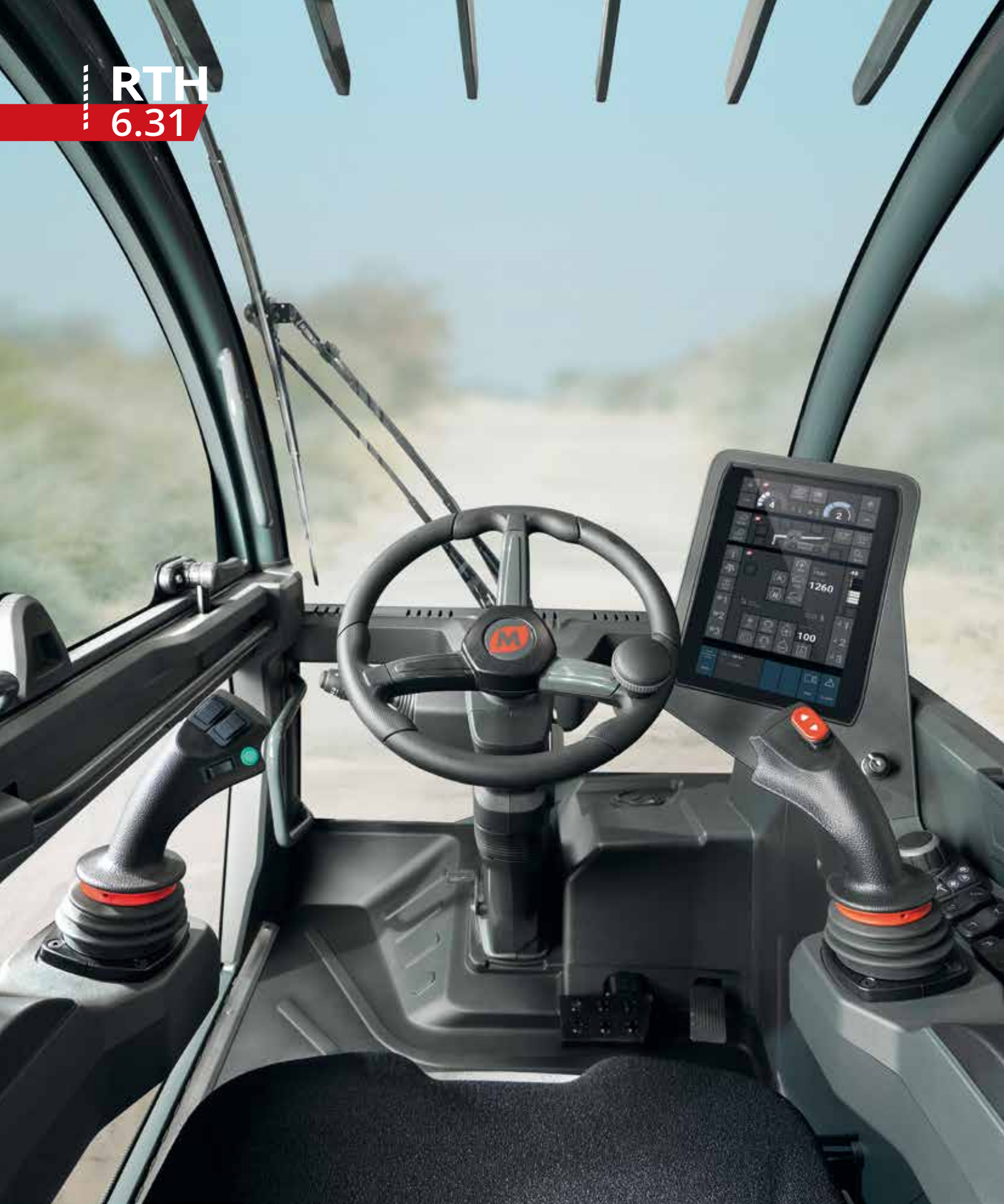

CAB

Best-in-class
safety and visibility



PERFORMANCE

Unrivalled lifting
performance



LOAD LIVE DIAGRAM

Three real-time dynamic
load charts

Load chart with
FULLY EXTENDED STABILISERS (360°)

ATT-03-004

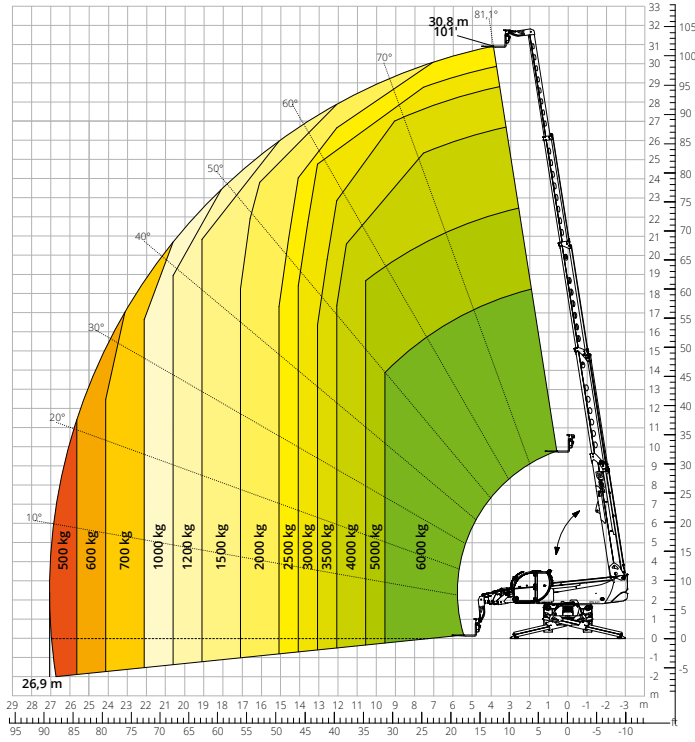

Load chart
FRONT ATTACHMENT ON TYRES

ATT-08-001

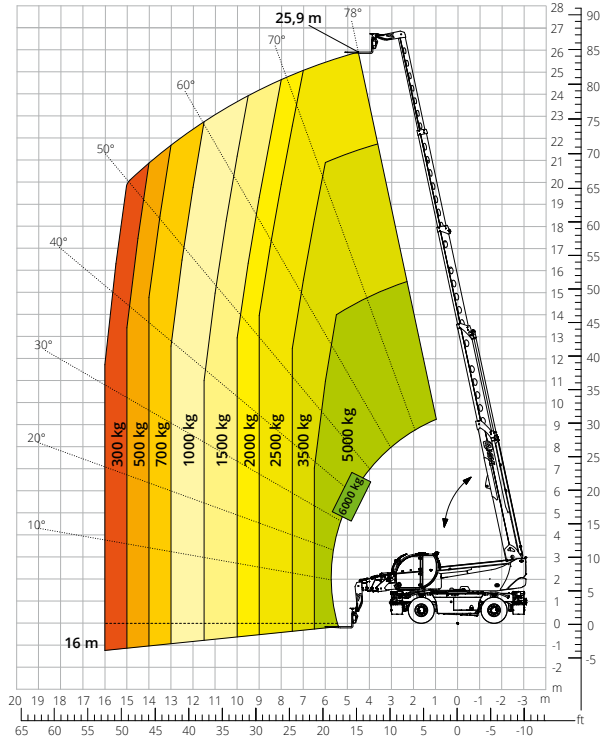

Load chart with
WINCH, 3,500 kg

ATT - 02 - 002

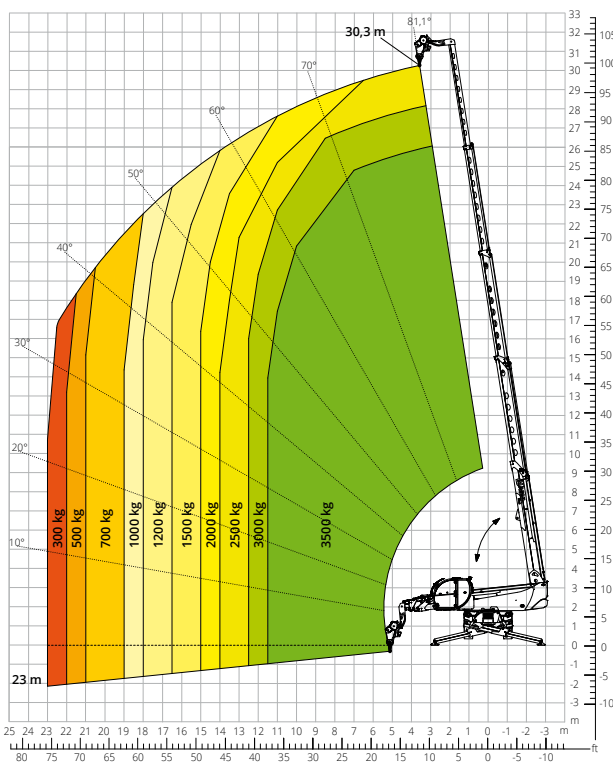

Load chart with
WINCH, 6,000 kg

ATT - 02 - 004

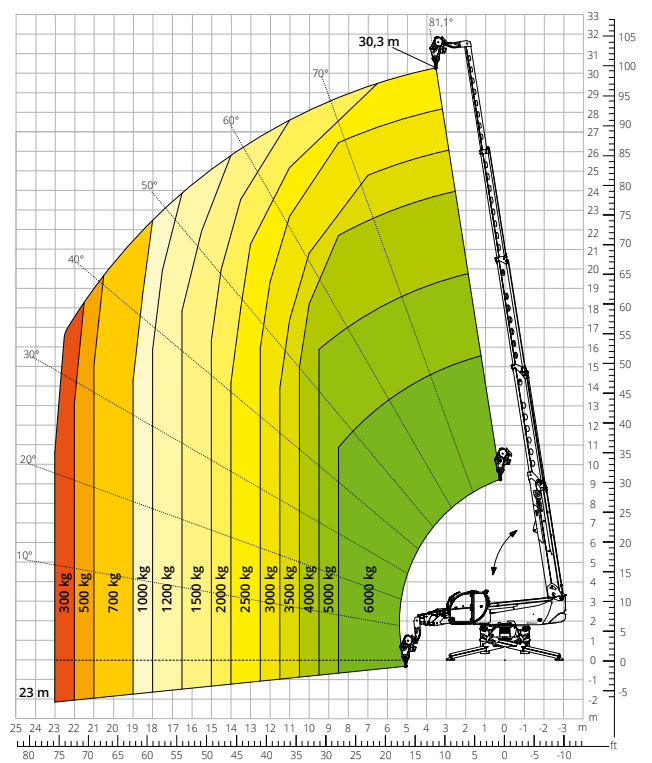

Load chart with
JIB WITH WINCH, 1,500 kg
ATT - 04 - 011

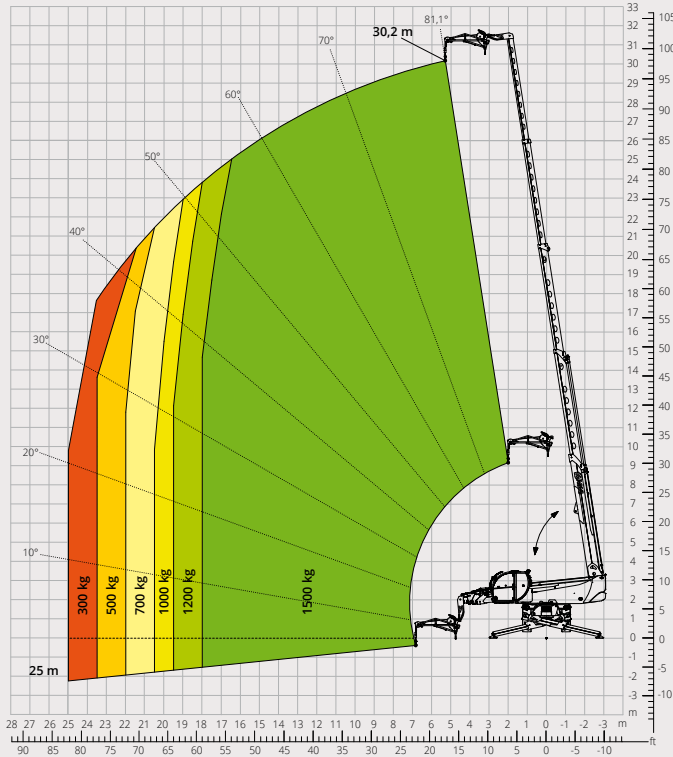

Load chart with
JIB WITH WINCH, 2,000 kg
ATT - 04 - 015

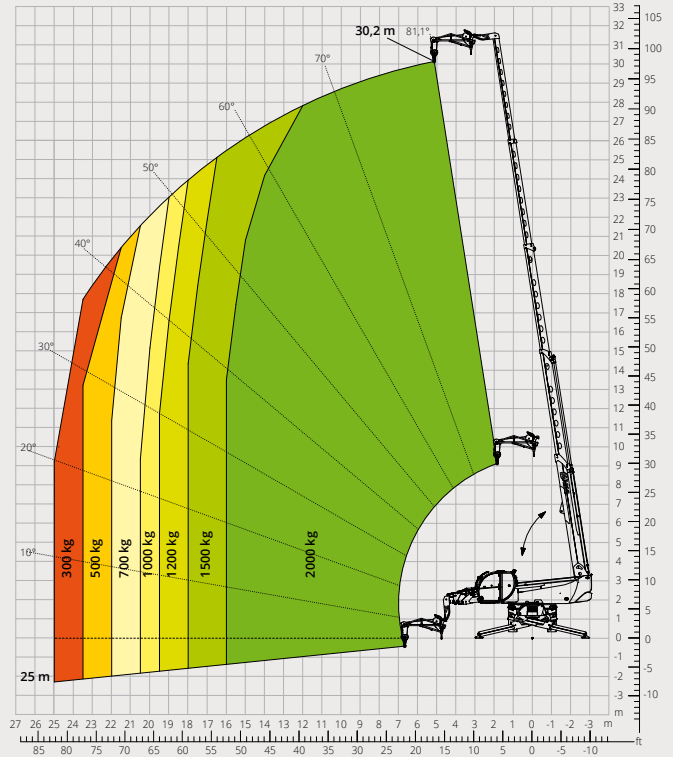

Load chart with
JIB WITH WINCH, 3,000 kg
ATT - 04 - 019

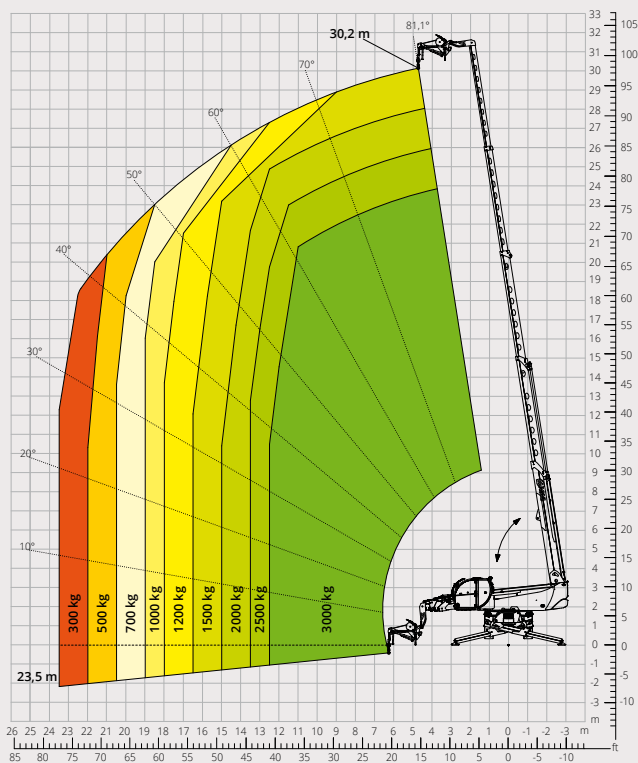

Load chart with
JIB, 2,000 kg
ATT - 04 - 013

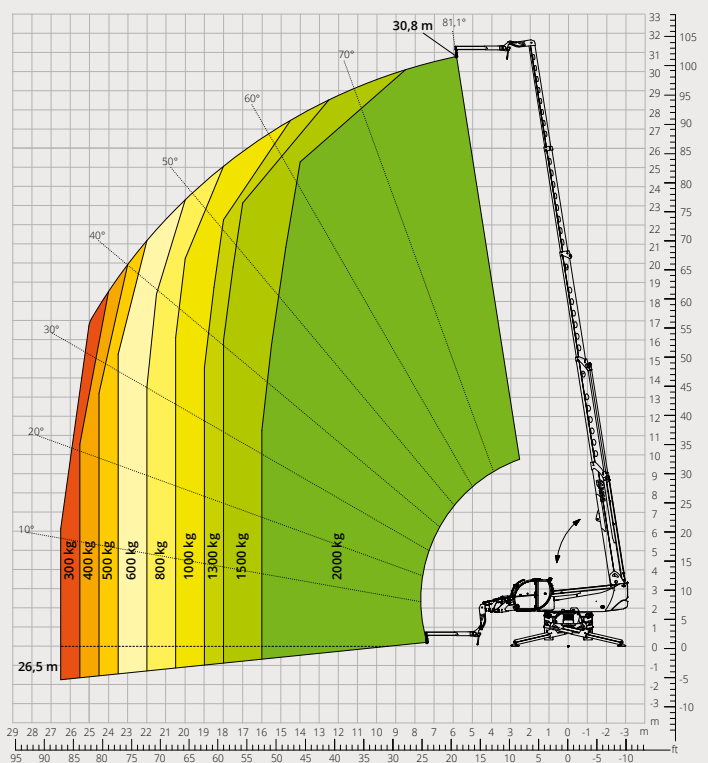

Load chart with
HOOK, 6,000 kg
ATT - 05 - 001

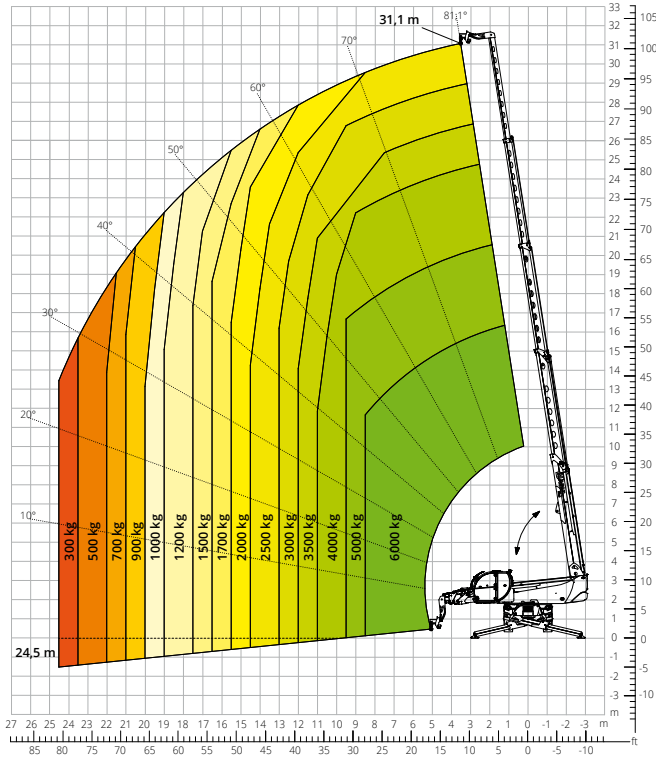

Load chart with
ROTATING EXTENDABLE PLATFORM, 500 kg
ATT - 01 - 005

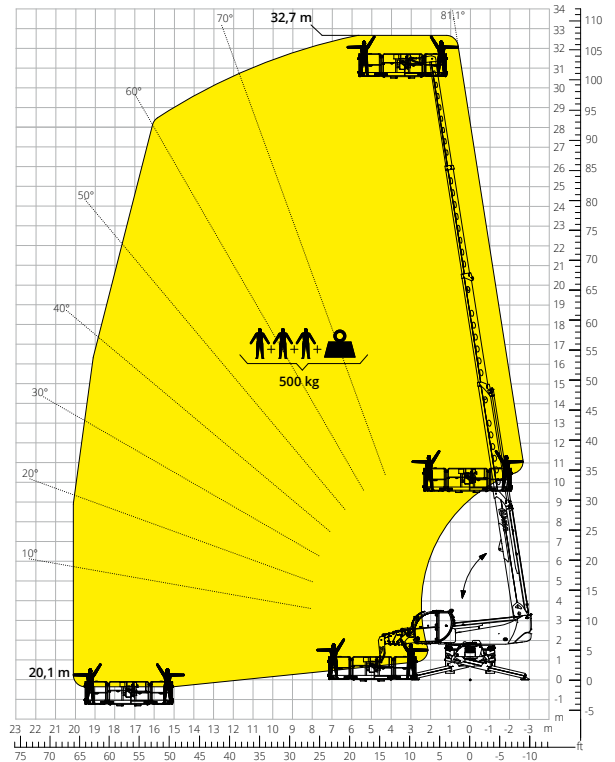

Load chart with
ROTATING EXTENDABLE PLATFORM,
1,000 kg
ATT - 01 - 016

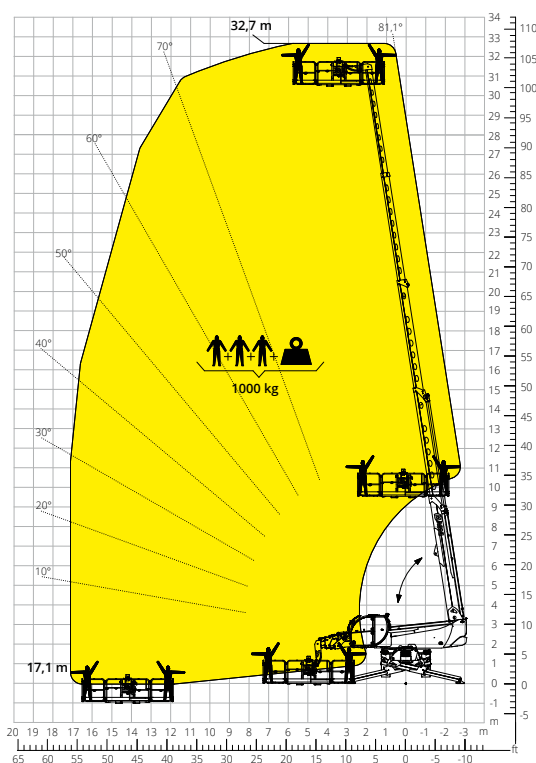

Load chart with
PLATFORM, 500 kg, WITH WINCH,
600 kg
ATT - 01 - 026

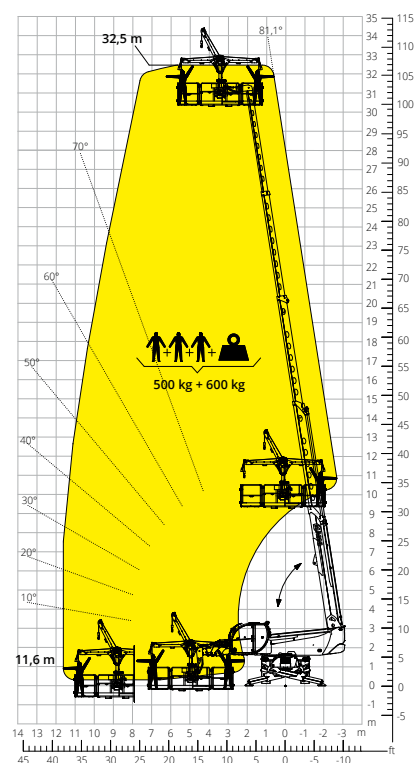

Machine model	Rotating telescopic handler	RTH 6.31	
	Maximum lifting capacity	6,000 kg	
	Maximum lifting height	30.80 m	
	Maximum reach	26.90 m	
	Rotation	360° (continuous)	
Stabilisers	Type	Scissor stabilisers with single telescopic extension (Magni patent)	
Engine	Model	Volvo TAD 582 VE Stage V	Volvo TAD 552 VE Stage IIIA
	Rated power	160 kW (218 hp) at 2,300 rpm	160 kW (218 hp) at 2,200 rpm
	Maximum torque	925 Nm at 1,380 rpm	910 Nm at 1,450 rpm
	Displacement	5,130 cm ³	
	Cylinders	4 in line	
	Engine type	Turbocharged direct injection diesel	
	Cooling system	Water – intercooler	
Transmission	Type	Hydraulic	
	Maximum pressure	480 bar	
	Gearbox	2 speeds forward-reverse	
Axles and brakes	Type	Axles with planetary gearboxes	
	Front axle	Oscillating and steering with levelling, +/-8°	
	Rear axle	Oscillating and steering with hydraulic lock	
	No. of steering wheels	4WS	
	Steering mode	Frontal/Concentric/Crab	
	Service brake	Hydraulically operated wet multi-disk brakes on each axle	
	Parking brake	Hydraulic with negative action	
Performance	Tyre sizes	445/65 R22.5	
	Max. travel speed	40 km/h	
	Drawbar pull	89 kN	
	Maximum mass towable on hook	5,000 kg	
	Gradeability	41%	
Weights	Turning radius (at forks)	6,730 mm	
	Total unladen*	22,700 kg	
	Front axle unladen (boom retracted and lowered)*	10,500 kg	
Tank and system capacities	Rear axle unladen (boom retracted and lowered)*	12,200 kg	
	Diesel fuel	270 l	270 l
	AdBlue	40 l	/
	Hydraulic fluid	160 l	160 l
	Engine oil	16 l	16 l
	Cooling liquid	40 l	40 l
Hydraulic circuit for movements	Circuit type	Load sensing	
	Service pump	Variable displacement	
	Max. hydraulic flow rate	170 l/min	
	Max. boom head flow rate	75 l/min	
	Max. working pressure	350 bar	
	Distributor for boom and turret movements	SIL 2 electro-proportional valve	
Standards met	Movements control	2 two-axis Danfoss joysticks with deadman safety device	
	2006/42/EC: EU Machinery Directive		
	2016/1628: EU Regulation on the emissions of stage V engines		
	EN 1459-X: Relating to standards on the safety requirements for variable reach machines		
EN 280/EN 280-1/EN 280-2: standards relating to mobile elevating work platforms (if available)			
ROPS/level 2 FOPS: relating to the standards for protective structures			

The data given in this brochure are provided for information purposes and are subject to change without prior notice.

All images are purely guideline and might not give an exact representation of the product.

**the stated weight refers to the vehicle unladen with standard equipment and may vary depending on the chosen configuration.*

The standard machine configuration includes:

CAB

- “Easy access” system
- Premium tilting seat with air suspension and headrest
- Adjustable steering column
- Analogue joypad
- Adjustable sunblind
- Heating
- Air conditioning
- FM/AM radio with USB and Bluetooth connectivity
- Ambient LED lights
- USB Type-A and Type-C (5 V) inputs

REAL TIME INFORMATION

- Touchscreen, 12”
- MCTS – Magni Combi Touch System on-board software
- Automatic RFID tools recognition system
- LMI – Load Moment Indicator
- LLD – Live Load Diagram
- Onboard and remote integrated diagnostics
- Reversing camera with image integrated in the MCTS

TECHNICAL SPECIFICATIONS

- Q-Fit standard
- Provision for platform
- Advanced three-line CAN BUS system
- Automatic levelling system for outriggers
- Automatic front and rear wheel alignment
- High-precision turret rotation motor by Liebherr
- Automatic parking brake
- Mechanical battery cut-off in engine compartment
- Electrical system: 24 V – IP67

SERVICE

- MyMagni by Trackunit connectivity system (2 years)
- Warranty: 24 months/2,000 hours