

# 696+ 2-DK

## INCLINED SCREEN



STRONG **HERITAGE**, STRONG **FUTURE**

 **FINLAY**®  
A TEREX BRAND

# 696+ 2-DK

## INCLINED SCREEN



The Finlay® 696 2-deck inclined screen has been developed to fulfil the demands of high production producers in quarrying, mining, sand and gravel, coal, woodchip and topsoil applications.

The new high energy screenbox features two full size 6.1m x 1.7m (20' x 5' 7") to give a total screening area of 20.74m<sup>2</sup> (223ft<sup>2</sup>). The 8m<sup>3</sup> (10.5yd<sup>3</sup>) hopper / feeder is fitted with variable speed belt feeder to ensure consistent flow of material and can be fitted with remote tipping grid or double deck vibrating grid.

Operator benefits include a quick set-up time (typically under 30 minutes) with hydraulically folding screenbox catwalks and product conveyors. The compact transport envelope enables the machine to be transported between jobsites with ease.

The model is available with hybrid technology consisting of on-board electrical motors permitting the flexibility to run the plant from an outside power supply or standard on-board engine

### FEATURES:

- Simple and intuitive folding mechanism for the onboard product conveyors for ease of deployment and onsite movement.
- Hydraulic folding catwalks as standard for improved onsite efficiency and to enable rapid screenbox deployment.
- The hydraulics system has been engineered to provide the optimum balance of power and efficiency.
- Screen box angle can be hydraulically adjusted to an angle between 18° and 32°.
- T-Link telematics hardware and software along with free seven year data subscription are fitted and installed as standard.

### TRANSPORT DIMENSIONS

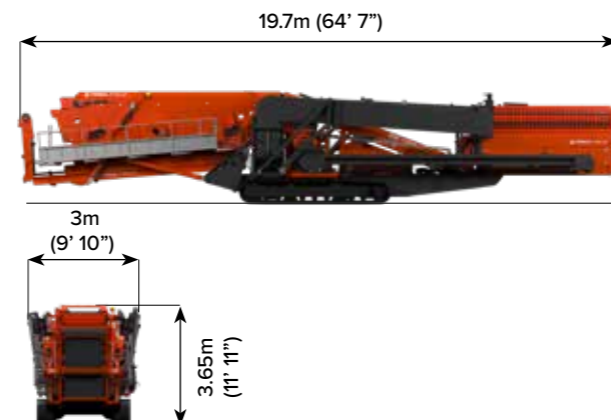

### WORKING DIMENSION

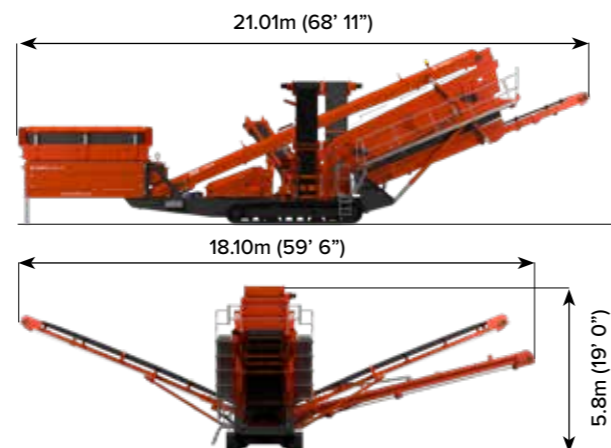

### MACHINE WEIGHT:

33,800KG (74,550LBS)  
WITH TIPPING GRID

### 1 HOPPER / FEEDER

Hopper Capacity: 8m<sup>3</sup> (10.5yd<sup>3</sup>)  
Feed height: 2.5m (8')  
Feed in width: 4.2m (13' 9") (grid wing plates)  
Beltfeeder belt width: 1.2m (48")  
Speed: variable, 0 - 16 mpm (0 - 53' per min)

### 2 UNDERCARRIAGE

Shoe Width: 500mm (20")  
Gradeability: 32.6°  
Raking Angle: 9°

### 3 MIDDLE GRADE CONVEYOR

Belt width: 800mm (32")  
Working Angle: 22°  
Speed: variable speed, 0 - 90 mpm (410' per min)  
Discharge Height: 5.1m (16' 9")  
Stockpile capacity: 228m<sup>3</sup> (298yd<sup>3</sup>)

### 4 MAIN CONVEYOR

Belt width: 1.2m (48")  
Belt Speed: 92 mpm (302' per min)  
Steel skirted full length of conveyor

### 5 SCREEN BOX

All decks: 6.1m x 1.7m (20' x 5' 7") All 3 Decks  
Hydraulic Folding Catwalks  
Screen Angle: 18° - 32°, hydraulic adjust

### 6 OVERSIZE CONVEYOR

Belt width: 800mm (32")  
Working Angle: 22°  
Speed: variable speed, 0 - 90 mpm (295' per min)  
Discharge Height: 5.1m (16' 9")  
Stockpile capacity: 228m<sup>3</sup> (298yd<sup>3</sup>)

### 7 FINES CONVEYOR

Belt width: 1.2m (48")  
Working Angle: Variable 27.5° (Max)  
Speed: variable speed max 125mpm (410' per min)  
Standard Discharge Height: 5.5m (18')  
Stockpile capacity: 285m<sup>3</sup> (373yd<sup>3</sup>)



### T-LINK TELEMATICS

T-Link telematics hardware and software along with free seven year data subscription are fitted and installed as standard.





The material in this document is for information only and is subject to change without notice.

Finlay® assumes no liability resulting from errors or omissions in this document, or from the use of the information contained herein.

Due to continual product development we reserve the right to change specifications without notice. Product performance figures given in this brochure are for guidance purposes only, this information does not constitute an expressed or implied warranty or guarantee, but shows test examples. These results will vary depending on application. Photographs are for illustrative purposes only; some or all of the machines in the illustrations may be fitted with optional extras. Please check with your Dealer for details on optional extras.

Published and Printed in 2022

[www.terex.com/finlay](http://www.terex.com/finlay)

E: [sales@terexfinlay.com](mailto:sales@terexfinlay.com)

T: +44 28 82 418 700

